

**YOUR NUMBER ONE
CHOICE AND SOURCE
FOR QUALITY DRYER
VENT BOXES.**



DBX1017FR6

- ✓ Meets IRC and IMC Code
- ✓ Optional Snap On Trim Ring
- ✓ Reduces Labor Costs

DBX1017FR6

METAL DRYER VENT BOX

The DBX1017FR6 Metal Dryer Vent Box is powder-coated white for a clean, finished appearance. Measuring 10" wide by 17" tall, it is designed to fit seamlessly into a 2x6 framed wall. The unit is tested and rated to meet up to 2-hour equal F&T fire rating requirements for through-penetration fire-rated systems. An optional snap-on trim ring is available for a sleek, professional installation.



CALL TODAY:

480.346.8240

SUPPLY HOUSES NATIONWIDE



newconstructionsolutions.com

**CONSTRUCTION
SOLUTIONS**

MANUFACTURER & DISTRIBUTOR OF SPECIALTY BUILDING PRODUCTS

RevNo	Revision note	Date	Signature	Checked
2		10/26/2021	SR	SM

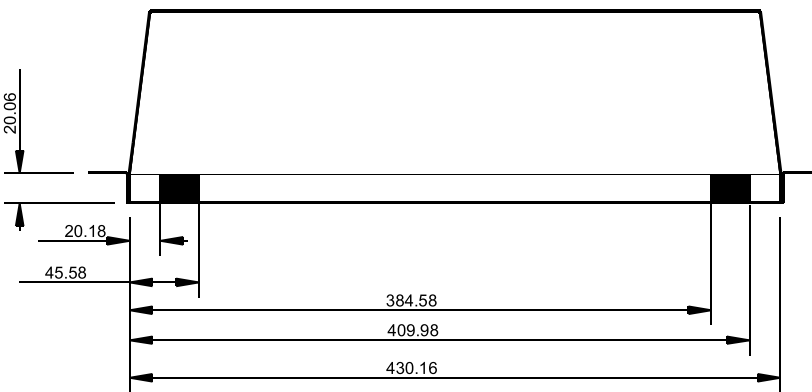
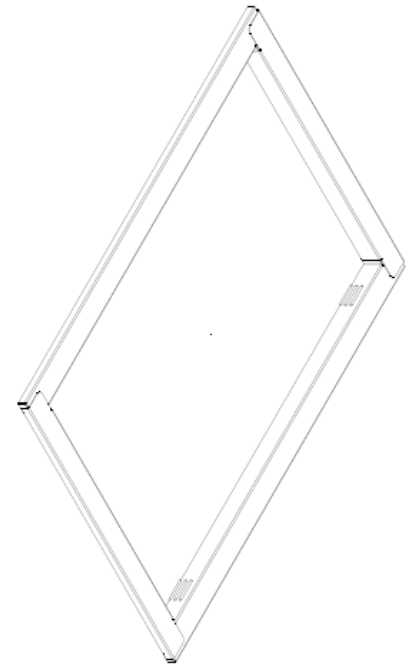
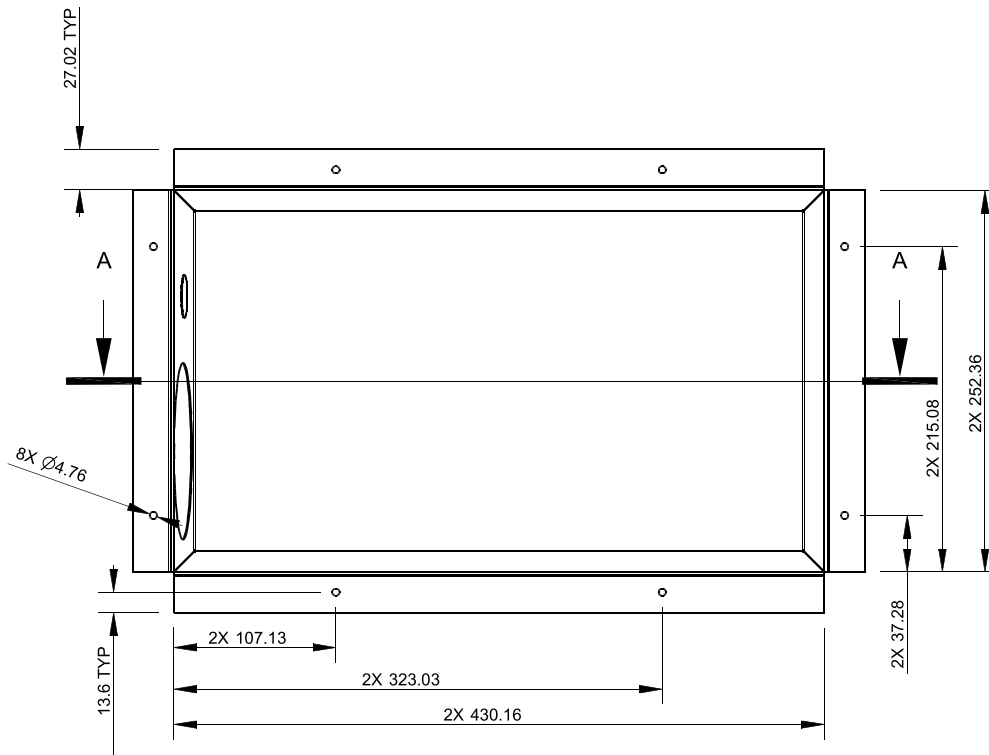
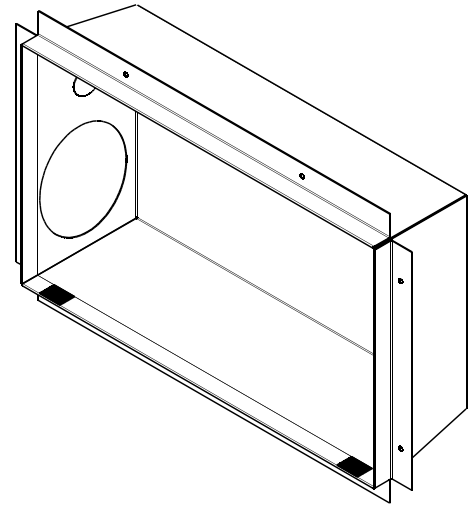
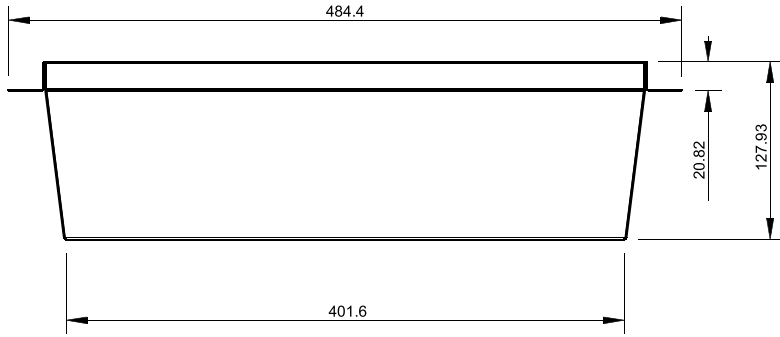

Section A-A

DBX1017FR-6



DBX1017FR6 DRYER VENT BOX

REQUEST FOR ALTERNATE TO BID

(SUBMITTAL FORM ATTACHED)

.....requests to add and/or substitute the DBX1017FR Dryer Vent Box, manufactured by Construction Solutions, on the following..... project.

THE UTILIZATION OF THE DBX1017FR WILL EMPLOY THE FOLLOWING BENEFITS:

ATTRACTIVE

Features a sleek, powder-coated white finish with an optional snap-on trim ring for added versatility.

PRACTICAL

Conceals the dryer vent and gas valve connection in the wall away from harms way, available for easy access hook-up connection.

DURABLE

Metal Dryer Vent Box. Easy to clean and is heat resistant. Meets IMC and IRC code requirements.

ADDED VALUE

The **DBX1017FR** recoups up to five feet of living space by positioning the dryer closer to the wall and even with the washer. The code required “**length identification**” label is provided in the box.

MULTIFUNCTIONAL

The **DBX1017FR** is multi-positional for field conversion. It can be used for up or down dryer venting. It meets 1 hour equal F&T rating if required.



SUBMITTAL FORM

PROJECT INFORMATION

Project Name :

Project Address :

City :

State/zip :

Start Date For
Dryer Venting :

Builder/Contractor :

CONTRACTOR INFORMATION

THIS PRODUCT SUBMITTAL PACKAGE HAS BEEN FURNISHED BY :

Contractor Name :

Address :

City :

State/zip :

Contact :

Phone/Fax :

Email :

SUBMITTAL INFORMATION

THIS SUBMITTAL PACKAGE INCLUDES :

The DBX1017FR6 – Metal Dryer Vent Box :

Installation Instructions :



CONSTRUCTION SOLUTIONS

 22415 N 18th Dr.
Phoenix, AZ. 85027

 480-346-8240

 www.newconstructionsolutions.com

DBX1017FR

Recessed Vent Receptacle
Installation Guidelines &
Product Information

INSTALLATION INSTRUCTIONS FOR THE DBX1017FR DRYER VENT BOX

THE DBX1017FR IS 10" WIDE X 17" TALL X 4.25" DEEP. **MEETS THE 1-HOUR EQUAL F&T "THROUGH PENETRATION FIRESTOP SYSTEM REQUIREMENTS.** THIS 4.25" DEEP BOX IS INSTALLED IN 2X6 WOOD OR 6" METAL FRAMING. THE DBX1017FR IS POWDER COATED WHITE.

FOR OPTIMUM RESULTS INSTALL THE DBX1017FR FOR UP/DOWN VENTING IN 2X6 WOOD OR 6" METAL FRAMING AS FOLLOWS:

BOX INSTALLATION - 16" ON-CENTER SPACING FOR STANDARD FRAMING OR FIRE RATING REQUIREMENT. IT CAN BE INSTALLED IN 24" ON-CENTER IN NON-RATED WALLS.

ORIENT BOX TO MATCH DESIRED VENTING DIRECTION. ALLOW A MINIMUM OF 2" OF VENT PIPE TO EXTEND INTO THE BOX.

IF GAS LINE IS TO BE INSTALLED, INSERT INTO KNOCKOUT PROVIDED.

BOX CAN BE INSTALLED IN ANY LOCATION IN THE STUD CAVITY TO MEET DESIRED POSITION FOR DRYER LOCATION.

ATTACH BOX TO ONE STUD AND BOTTOM STUD PLATE USING 1 1/4" SCREWS OR NAILS. IF POSITIONING IN THE STUD CAVITY TO ACCOMMODATE A STACKED DRYER CONFIGURATION ATTACH BLOCKING BELOW THE BOX AND ATTACH THE BOX TO ONE STUD AND THE BLOCKING.

INSTALLATION INSTRUCTIONS FOR A 1 HOUR FIRE WALL REQUIREMENT

To achieve a penetration firestop system rating (one-hour equal F&T) 2" x 6" (50mm x 152mm) **wood framing**, 16" O.C. (406mm) is required. The DBX1017FR is to be installed in accordance with the QAI assembly description. Insulation to be minimum R-19 fiberglass batt insulation that is classified as non-combustible as defined by ASTM E136 and CAN/ULC-S114, min thickness 6 inches. Insulation to be installed in all areas including between the stud and dryer vent box. The batt may be split to half the thickness to be able to compress it behind the box. The dryer vent box is 10" wide x 17" high x 4.25" deep with a 1" flange. The dryer vent box is fastened to the stud and sill with 1 1/2" screws. The 4" galvanized vent pipe is installed in the opening and caulked at the vent/box interface using one of the following caulks: PFP 4800DW/Hilti FS-ONE MAX/STI LC Endothermic Firestop Sealant/3M Fire Barrier Sealant CP 25WB+. Type X gypsum wallboard 5/8" complying with ASTM C 1396 is installed on stud face. The cavity containing the Dryer Vent Box shall have a layer of 5/8" Type X gypsum board placed behind the box. The gypsum board shall be fastened to two 3/4" (19mm) by 1 1/2" (38mm) pieces of wood fastened to the stud with wood screws such that the gypsum board will be flush with the 1 1/2" (38mm) face of the studs prior to fastening the sheathing. The gypsum board shall be fastened with #6 1 5/8" (41mm) drywall screws.

Installation for **25-gauge steel framing** is the same as above for the DBX1017FR dryer vent box.

Exception: insulation in the dryer vent box cavity shall be mineral wool thermal insulation in compliance with ASTM C612 Type II, III or IVA. ASTM C612 Type II and III mineral wool insulation must also be non-combustible as defined by ASTM E 136 and CAN/ULC-S114, min 4.0 lb. (64kg/m³) density. A minimum 1" mineral wool board or batt shall be installed behind the Dryer Vent Box including between the box and the stud. In addition, a minimum R-19 fiberglass batt insulation meeting ASTM E 136 and CAN/ULC S-114 shall be installed in the adjacent stud cavities.

INSTALLATION INSTRUCTIONS FOR A 2 HOUR FIRE WALL REQUIREMENT

Follow the installation instructions for the 1 Hour Fire. In addition, you will need an extra layer of 5/8 in type X Gypsum. (16 mm) on each face of the wall - And make the following modifications:

Gypsum Application: Installed vertically with joints offset 24-inches (610 mm) from base layer. The second layer of 5/8 in. (16 mm) Type X is attached with minimum #6 x 2-1/4 inch (57 mm) self-drilling drywall screws spaced at 8 in. (203 mm) around the perimeter and 12 in. (305 mm) in the field.

****A 2-hour Rating cannot be achieved in a Load bearing wall.****

**QAI Listing B1072-1C Construction Solutions
 Dryer Vent Boxes
 CAN/ULC S115, ASTM E814
 1 Hour Membrane Penetration Assembly
 Non-Load Bearing**

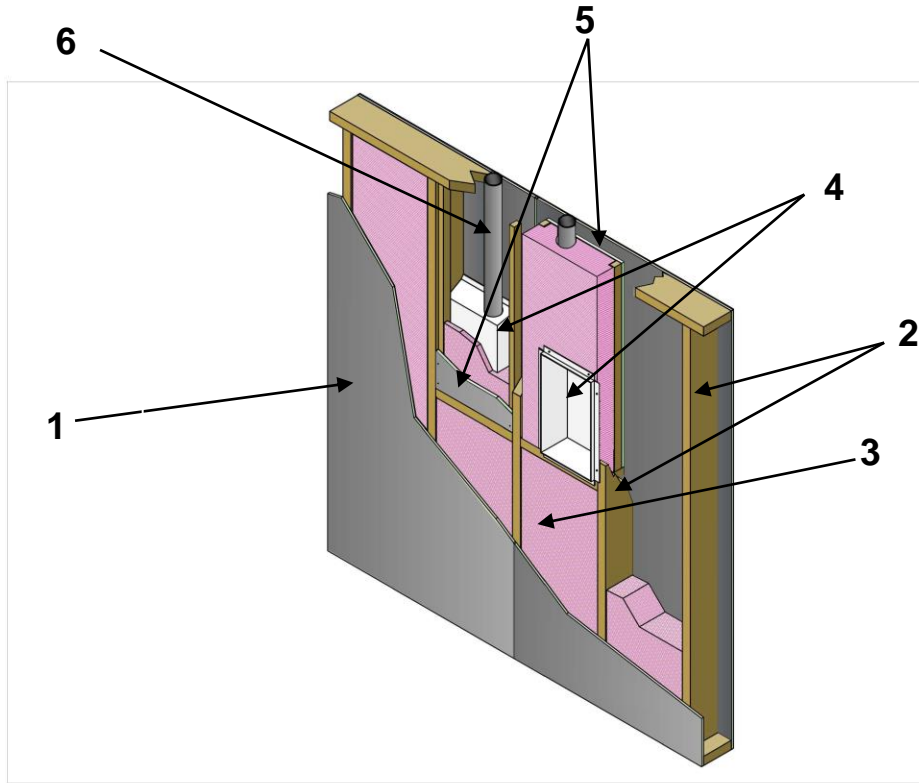

No.	COMPONENT	DESCRIPTION	
1	Gypsum Board Sheathing	Type:	Type X gypsum wallboard complying with ASTM C1396 and labeled by an approved agency.
		Thickness:	Single layer of 5/8 in. (16 mm) on each face of the wall.
		Application:	Sheathing is to be fastened to studs with #6 x 1-5/8 in. (41 mm) long coarse thread drywall screws spaced at 8 in. (203 mm) on center. Joints to be taped and mudded, and fastener heads to be mudded.
2	Wall Studs	Stud Type:	Minimum nominal 2 x 6 in. (38 x 140 mm) wood studs.
		Stud Spaced	Maximum 16 in. (406 mm) on center.
3	Insulation	Type:	Minimum R-19 fiberglass batt insulation that is classified as non-combustible as defined by ASTM E136 and CAN/ULC-S114.
		Minimum Thickness:	6 inch (152 mm).
		Installation:	Fiberglass batt must be installed in all areas including between the stud and dryer vent box. The batt may be split to half the thickness in order to be able to compress it behind the box.

No.	COMPONENT	DESCRIPTION	
4	Dryer Vent Box	Certified Manufacturer:	Construction Solutions.
		Certified Product:	DBX1000M 4.0 in. Construction Solutions dryer vent box kit. DBX1017FR6 4.25 in. Construction Solutions dryer vent box kit. DBX1017FR4 3.5 in. Construction Solutions dryer vent box kit.
		Box Dimensions:	DBX1017FR6 4.25 in.: 10 in. (254 mm) wide by 17 in. (432 mm) high by 4.25 in. (108 mm) deep with a 1 in. (25 mm) flange. box is formed from 24 Gauge steel.
			DBX1017FR4 3.5 in.: 10.77 in. wide by 17.82 in. high by 4 ¼ in. deep with a 1 in. flange. A 3.157 in. cut out for the dryer vent. 1-1/8 in. knockout on the top of the box. The box is formed from 24 Gauge steel.
			DBX1000M 4 in.: 10 in. (254 mm) wide by 17 in. (432 mm) high by 3-1/2 in. (89 mm) deep with a 1-1/4 in. (32 mm) flange. A 3 x 5 in. (76 x 127 mm) oval cut out for the dryer vent on the top and 1-1/8 in. (29 mm) knockouts on the top and bottom for gas hook up. The box is formed from 22-gauge galvanized steel.
		Trim Ring Dimensions:	9-7/8 in. (251 mm) wide by 16-7/8 in. (429 mm) high by 1-5/8 in. (16 mm) deep with a 1-5/16 in. (33 mm) flange. The trim ring is of 25 gauge galvanized steel.
		Sealant:	PFP 4800DW Hilti FS-ONE MAX STI LC Endothermic Firestop Sealant 3M Fire Barrier Sealant CP 25WB+ WF300 Intumescent Caulking Foil Tape listed to UL 723
Installation:	The dryer vent box is fastened to the stud and sill through two holes on the side and bottom of the box using #8 x 1-1/2 in. (38 mm) wood screws. The galvanized steel dryer vent is inserted through the top of the box then caulked at the vent/box interface. The opening cut into the gypsum board shall be a maximum of 10-1/2 in. (267 mm) wide by 17-1/2 in. (445 mm) high. Only one box is permitted per stud cavity.		
5	Gypsum Board (Dryer Box Cavity)	Type:	Type X gypsum wallboard complying with ASTM C1396 and labeled by an approved agency.
		Thickness:	Single layer of 5/8 in. (16 mm).
		Application:	The cavity containing the dryer vent box shall have a layer of Type X gypsum placed behind the box. The gypsum shall be fastened to two 3/4 in. (19 mm) by 1-1/2 in. (38 mm) pieces of wood fastened to the stud with wood screws such that the gypsum will be flush with the 1-1/2 in. (38 mm) face of the studs prior to fastening the sheathing. The gypsum board shall be fastened with no. 6 x 1-5/8 in. (41 mm) drywall screws.
6	Vent Pipe	Size:	4 in. (101 mm) round.
		Type:	26-gauge galvanized steel.

Visit the QAI Online Listing Directory located at www.qai.org for the most up to date version of this Listing and to validate that this QAI Listing is active.

**QAI Listing B1072-1D Construction Solutions
 Dryer Vent Boxes
 CAN/ULC S115, ASTM E814
 1 Hour Membrane Penetration Assembly
 Non-Load Bearing**

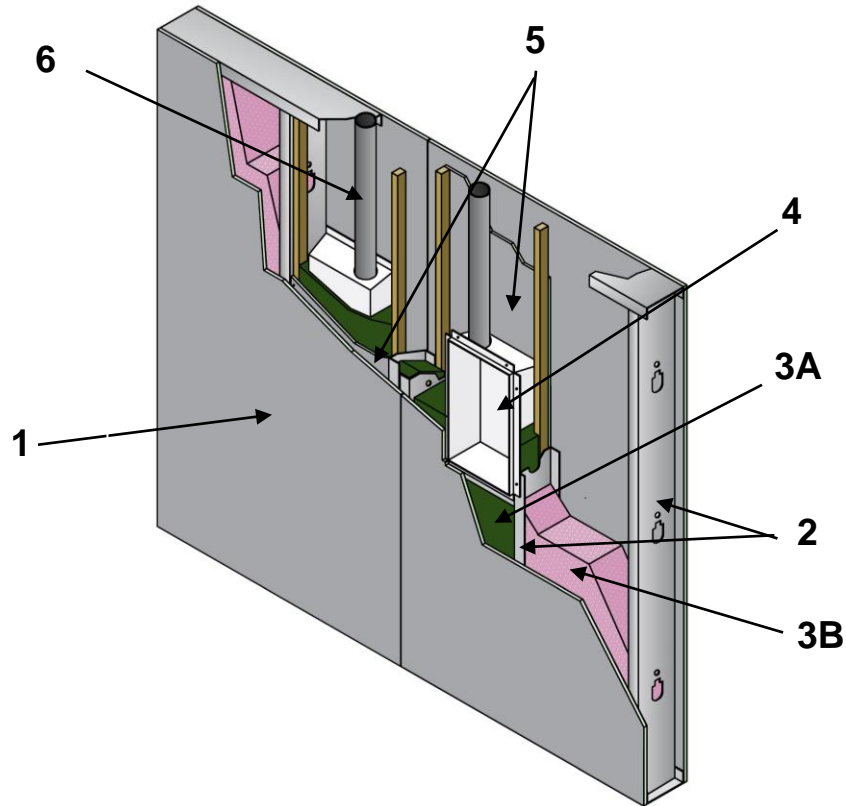

No.	COMPONENT	DESCRIPTION	
1	Gypsum Board Sheathing	Type:	Type X gypsum wallboard complying with ASTM C1396 and labeled by an approved agency.
		Thickness:	Single layer of 5/8 in. (16 mm) on each face of the wall.
		Application:	Sheathing is to be fastened to studs with #6 x 1-1/4 in. (32 mm) long self-drilling drywall screws spaced at 8 in. (203 mm) on center. Joints to be taped and mudded, and fastener heads to be mudded.
2	Wall Studs	Stud Type:	Minimum 1-1/4 x 6 in. (32 x 152 mm) steel.
		Gauge:	Minimum 25 Gauge.
		Stud Spaced	Maximum 16 in. (406 mm) on center.
3A	Insulation (Dryer Vent Box Cavity)	Type:	Mineral wool thermal insulation in compliance with ASTM C612 Type II, III or IVA. ASTM C612 Type II and III mineral wool insulation must also be non-combustible as defined by ASTM E136 and CAN/ULC-S114.
		Nominal Density:	Minimum 4.0 lb/ft ³ (64 kg/m ³).
		Installation:	A 1 in. mineral wool board or batt shall be installed behind the dryer vent box. The remainder of the cavity shall be filled with mineral wool including between the box and the stud.

No.	COMPONENT	DESCRIPTION	
3B	Insulation (Adjacent Cavities)	Type:	Minimum R-19 fiberglass batt insulation that is classified as non-combustible as defined by ASTM E136 and CAN/ULC-S114.
		Minimum Thickness:	6 inch (152 mm).
		Installation:	Fiberglass batt must be installed in the adjacent cavities.
4	Dryer Vent Box	Certified Manufacturer:	Construction Solutions
		Certified Products:	DBX1000M 4 in. Construction Solutions dryer vent box kit. DBX1017FR6 4.25 in. Construction Solutions dryer vent box kit. DBX1017FR4 3.5 in. Construction Solutions dryer vent box kit.
		Box Dimensions:	DBX1017FR6 4.25 in.: 10 in. (254 mm) wide by 17 in. (432 mm) high by 4.25 in. (108 mm) deep with a 1 in. (25 mm) flange. box is formed from 24 Gauge steel.
			DBX1017FR4 3.5 in.: 10.77 in. wide by 17.82 in. high by 4 ¼ in. deep with a 1 in. flange. A 3.157 in. cut out for the dryer vent. 1-1/8 in. knockout on the top of the box. The box is formed from 24 Gauge steel.
			DBX1000M 4 in.: 10 in. (254 mm) wide by 17 in. (432 mm) high by 3-1/2 in. (89 mm) deep with a 1-1/4 in. (32 mm) flange. A 3 x 5 in. (76 x 127 mm) oval cut out for the dryer vent on the top and 1-1/8 in. (29 mm) knockouts on the top and bottom for gas hook up. The box is formed from 22-gauge galvanized steel.
		Sealing:	PFP 4800DW Hilti FS-ONE MAX STI LC Endothermic Firestop Sealant 3M Fire Barrier Sealant CP 25WB+ WF300 Intumescent Caulking Foil Tape listed to UL 723
Installation:	The dryer vent box is fastened to the stud and sill through two holes on the side and bottom of the box using #8 x 5/8 in. (16 mm) steel stud screws. The galvanized steel dryer vent is inserted through the top of the box then caulked at the vent/box interface. The opening cut into the gypsum board shall be a maximum of 10-1/2 in. (267 mm) wide by 17-1/2 in. (445 mm) high. Only one box is permitted per stud cavity.		
5	Gypsum Board (Back of Dryer Box Cavity)	Type:	Type X gypsum wallboard complying with ASTM C1396 and labeled by an approved agency.
		Thickness:	Single layer of 5/8 in. (16 mm) .
		Application:	The cavity containing the dryer vent box shall have a layer of type X gypsum placed behind the box. The gypsum shall be fastened to two 3/4 in. (19 mm) by 1-1/2 in. (38 mm) pieces of wood fastened to the stud with steel stud screws such that the gypsum will be flush with the 1-1/4 in. (32 mm) face of the studs prior to fastening the sheathing. The gypsum board shall be fastened with no. 6 x 1-5/8 in. (41 mm) drywall screws.
6	Vent Pipe	Size:	4 in. (101 mm) round.
		Type:	26 Gauge galvanized steel.

Visit the QAI Online Listing Directory located at www.qai.org for the most up to date version of this Listing and to validate that this QAI Listing is active.

**QAI Listing B1072-1E Construction
 Dryer Vent Boxes
 CAN/ULC S115, ASTM E814
 1 Hour Membrane Penetration Assembly
 Load Bearing**

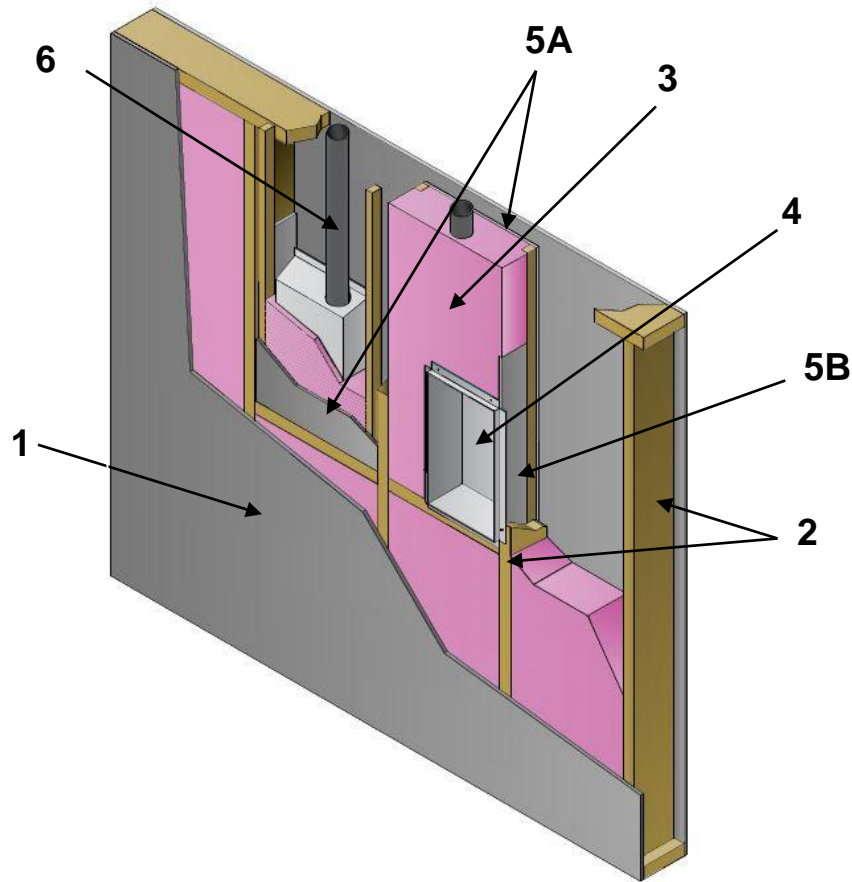

No.	COMPONENT	DESCRIPTION	
1	Gypsum Board Sheathing	Type:	Type X gypsum wallboard complying with ASTM C1396 and labeled by an approved agency.
		Thickness:	Single layer of 5/8 in. (16 mm) on each face of the wall.
		Application:	Sheathing is to be fastened to studs with #6 x 1-5/8 in. (41 mm) long coarse thread drywall screws spaced at 8 in. (203 mm) on center. Joints to be taped and mudded, and fastener heads to be mudded.
2	Wall Studs	Stud Type:	Minimum nominal 2 x 6 in. (38 x 140 mm) wood studs.
		Stud Spaced	Maximum 16 in. (406 mm) on center.
3A	Insulation	Type:	Minimum R-19 fiberglass batt insulation that is classified as non-combustible as defined by ASTM E136 and CAN/ULC-S114.
		Nominal Density:	6 inch (152 mm).
		Installation:	Fiberglass batt must be installed in all areas including between the stud and dryer vent box. The batt may be split to half the thickness in order to be able to compress it behind the box.

No.	COMPONENT	DESCRIPTION	
4	Dryer Vent Box	Certified Manufacturer:	Construction Solutions
		Certified Products:	DBX1000M 4 in. Construction Solutions dryer vent box kit. DBX1017FR6 4.25 in. Construction Solutions dryer vent box kit. DBX1017FR4 3.5 in. Construction Solutions dryer vent box kit.
		Box Dimensions:	DBX1017FR6 4.25 in.: 10 in. (254 mm) wide by 17 in. (432 mm) high by 4.25 in. (108 mm) deep with a 1 in. (25 mm) flange. box is formed from 24 Gauge steel.
			DBX1017FR4 3.5 in.: 10.77 in. wide by 17.82 in. high by 4 ¼ in. deep with a 1 in. flange. A 3.157 in. cut out for the dryer vent. 1-1/8 in. knockout on the top of the box. The box is formed from 24 Gauge steel.
			DBX1000M 4 in.: 10 in. (254 mm) wide by 17 in. (432 mm) high by 3-1/2 in. (89 mm) deep with a 1-1/4 in. (32 mm) flange. A 3 x 5 in. (76 x 127 mm) oval cut out for the dryer vent on the top and 1-1/8 in. (29 mm) knockouts on the top and bottom for gas hook up. The box is formed from 22-gauge galvanized steel.
		Sealing:	PFP 4800DW Hilti FS-ONE MAX STI LC Endothermic Firestop Sealant 3M Fire Barrier Sealant CP 25WB+ WF300 Intumescent Caulking Foil Tape listed to UL 723
		Installation:	The dryer vent box is fastened to the stud and sill through two holes on the side and bottom of the box using #8 x 1-1/2 in. (38 mm) wood screws. The galvanized steel dryer vent is inserted through the top of the box then caulked at the vent/box interface. The opening cut into the gypsum board shall be a maximum of 10-1/2 in. (267 mm) wide by 17-1/2 in. (445 mm) high. Only one box is permitted per stud cavity.
5A	Gypsum Board (Back of Dryer Box Cavity)	Type:	Type X gypsum wallboard complying with ASTM C1396 and labeled by an approved agency.
		Thickness:	Single layer of 5/8 in. (16 mm) .
		Application:	The cavity containing the dryer vent box shall have a layer of Type X gypsum placed behind the box. The gypsum shall be fastened to two 3/4 in. (19 mm) by 1-1/2 in. (38 mm) pieces of wood fastened to the stud with wood screws such that the gypsum will be flush with the 1-1/2 in. (38 mm) face of the studs prior to fastening the sheathing. The gypsum board shall be fastened with no. 6 x 1-5/8 in. (41 mm) drywall screws.
5B	Gypsum Board (Adjacent Stud of Dryer Box)	Type:	Type X gypsum wallboard complying with ASTM C1396 and labeled by an approved agency.
		Thickness:	Single layer of 5/8 in. (16 mm) .
		Application:	The adjacent stud to the dryer vent box shall have a layer of type X gypsum placed between the stud and the box. The gypsum shall extend 6 in. (152 mm) above the top of the box and fastened using six no. 6 x 1-5/8 in. (41 mm) Type W drywall screws.
6	Vent Pipe	Size:	4 in. (101 mm) round.
		Type:	26 Gauge galvanized steel.

Visit the QAI Online Listing Directory located at www.qai.org for the most up to date version of this Listing and to validate that this QAI Listing is active.

**QAI Listing B1072-1F Construction
 Dryer Vent Boxes
 CAN/ULC S115, ASTM E814
 1 Hour Membrane Penetration Assembly
 Load Bearing**

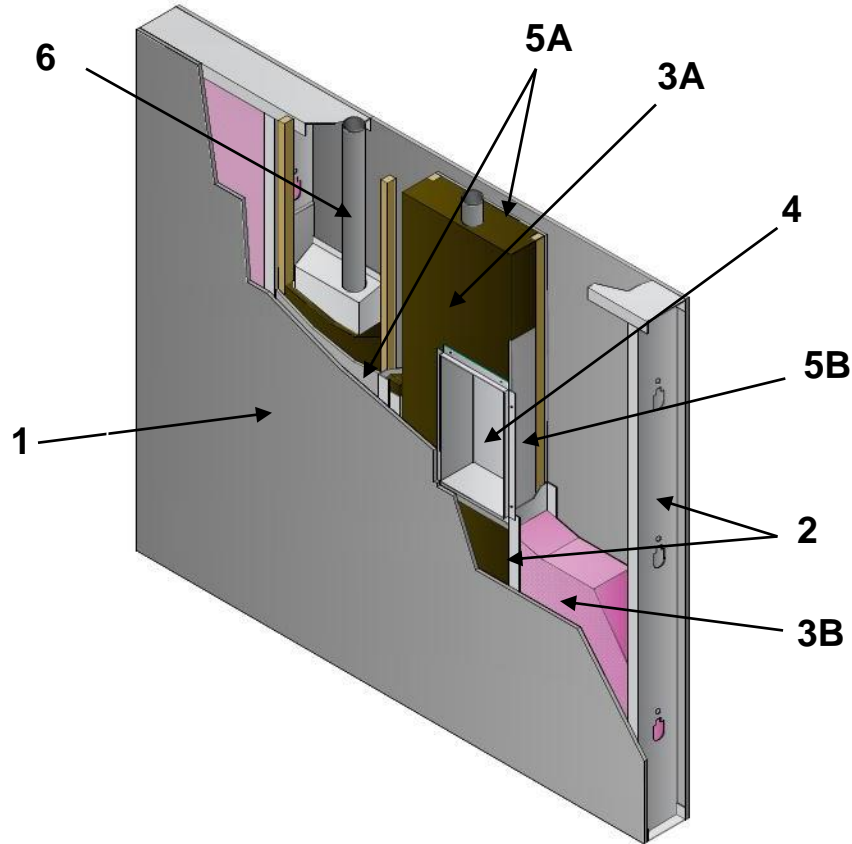

No.	COMPONENT	DESCRIPTION	
1	Gypsum Board Sheathing	Type:	Type X gypsum wallboard complying with ASTM C1396 and labeled by an approved agency.
		Thickness:	Single layer of 5/8 in. (16 mm) on each face of the wall.
		Application:	Sheathing is to be fastened to studs with #6 x 1-1/4 in. (32 mm) long self-drilling drywall screws spaced at 8 in. (203 mm) on center. Joints to be taped and mudded, and fastener heads to be mudded.
2	Wall Studs	Stud Type:	Minimum 1-1/4 x 6 in. (32 x 152 mm) steel.
		Gauge:	Minimum 25 Gauge.
		Stud Spaced	Maximum 16 in. (406 mm) on center.
3A	Insulation (Dryer Vent Box Cavity)	Type:	Mineral wool thermal insulation in compliance with ASTM C612 Type II, III or IVA. ASTM C612 Type II and III mineral wool insulation must also be non-combustible as defined by ASTM E136 and CAN/ULC-S114.
		Nominal Density:	Minimum 4.0 lb/ft ³ (64 kg/m ³).
		Installation:	A 1 in. mineral wool board or batt shall be installed behind the dryer vent box. The remainder of the cavity shall be filled with mineral wool including between the box and the stud.

No.	COMPONENT	DESCRIPTION	
3B	Insulation (Adjacent Cavities)	Type:	Minimum R-19 fiberglass batt insulation that is classified as non-combustible as defined by ASTM E136 and CAN/ULC-S114.
		Minimum Thickness:	6 inch (152 mm).
		Installation:	Fiberglass batt must be installed in the adjacent cavities.
4	Dryer Vent Box	Certified Manufacturer:	Construction Solutions
		Certified Products:	DBX1000M 4 in. Construction Solutions dryer vent box kit. DBX1017FR6 4.25 in. Construction Solutions dryer vent box kit. DBX1017FR4 3.5 in. Construction Solutions dryer vent box kit.
		Box Dimensions:	DBX1017FR6 4.25 in.: 10 in. (254 mm) wide by 17 in. (432 mm) high by 4.25 in. (108 mm) deep with a 1 in. (25 mm) flange. A 4 in. (102 mm) cut out for the dryer vent on the top and 1-1/8 in. (29 mm) knockout on the top. The box is formed from 24 Gauge steel.
			DBX1017FR4 3.5 in.: 10.77 in. wide by 17.82 in. high by 4 ¼ in. deep with a 1 in. flange. A 3.157 in. cut out for the dryer vent. 1-1/8 in. knockout on the top of the box. The box is formed from 24 Gauge steel.
			DBX1000M 4 in.: 10 in. (254 mm) wide by 17 in. (432 mm) high by 3-1/2 in. (89 mm) deep with a 1-1/4 in. (32 mm) flange. A 3 x 5 in. (76 x 127 mm) oval cut out for the dryer vent on the top and 1-1/8 in. (29 mm) knockouts on the top and bottom for gas hook up. The box is formed from 22-gauge galvanized steel.
		Sealing:	PFP 4800DW Hilti FS-ONE MAX STI LC Endothermic Firestop Sealant 3M Fire Barrier Sealant CP 25WB+ WF300 Intumescent Caulking Foil Tape listed to UL 723
Installation:	The dryer vent box is fastened to the stud and sill through two holes on the side and bottom of the box using #8 x 5/8 in. (16 mm) steel stud screws. The galvanized steel dryer vent is inserted through the top of the box then caulked at the vent/box interface. The opening cut into the gypsum board shall be a maximum of 10-1/2 in. (267 mm) wide by 17-1/2 in. (445 mm) high. Only one box is permitted per stud cavity.		
5A	Gypsum Board (Back of Dryer Box Cavity)	Type:	Type X gypsum wallboard complying with ASTM C1396 and labeled by an approved agency.
		Thickness:	Single layer of 5/8 in. (16 mm) .
		Application:	The cavity containing the dryer vent box shall have a layer of type X gypsum placed behind the box. The gypsum shall be fastened to two 3/4 in. (19 mm) by 1-1/2 in. (38 mm) pieces of wood fastened to the stud with steel stud screws such that the gypsum will be flush with the 1-1/4 in. (32 mm) face of the studs prior to fastening the sheathing. The gypsum board shall be fastened with no. 6 x 1-5/8 in. (41 mm) drywall screws.
5B	Gypsum Board (Adjacent Stud of Dryer Box)	Type:	Type X gypsum wallboard complying with ASTM C1396 and labeled by an approved agency.
		Thickness:	Single layer of 5/8 in. (16 mm) .
		Application:	The adjacent stud to the dryer vent box shall have a layer of type X gypsum placed between the stud and the box. The gypsum shall extend 6 in. (152 mm) above the top of the box and fastened using six no. 6 x 1-1/4 in. (32 mm) Type S drywall screws.
6	Vent Pipe	Size:	4 in. (101 mm) round.
		Type:	26 Gauge galvanized steel.

Visit the QAI Online Listing Directory located at www.qai.org for the most up to date version of this Listing and to validate that this QAI Listing is active.



**QAI Design B1072-1H – Construction Solutions – Dryer Vent Box
CAN/ULC S115 / ASTM E814 – 1 Hour & 2 Hour Membrane Penetration Assembly
Non-Load Bearing**

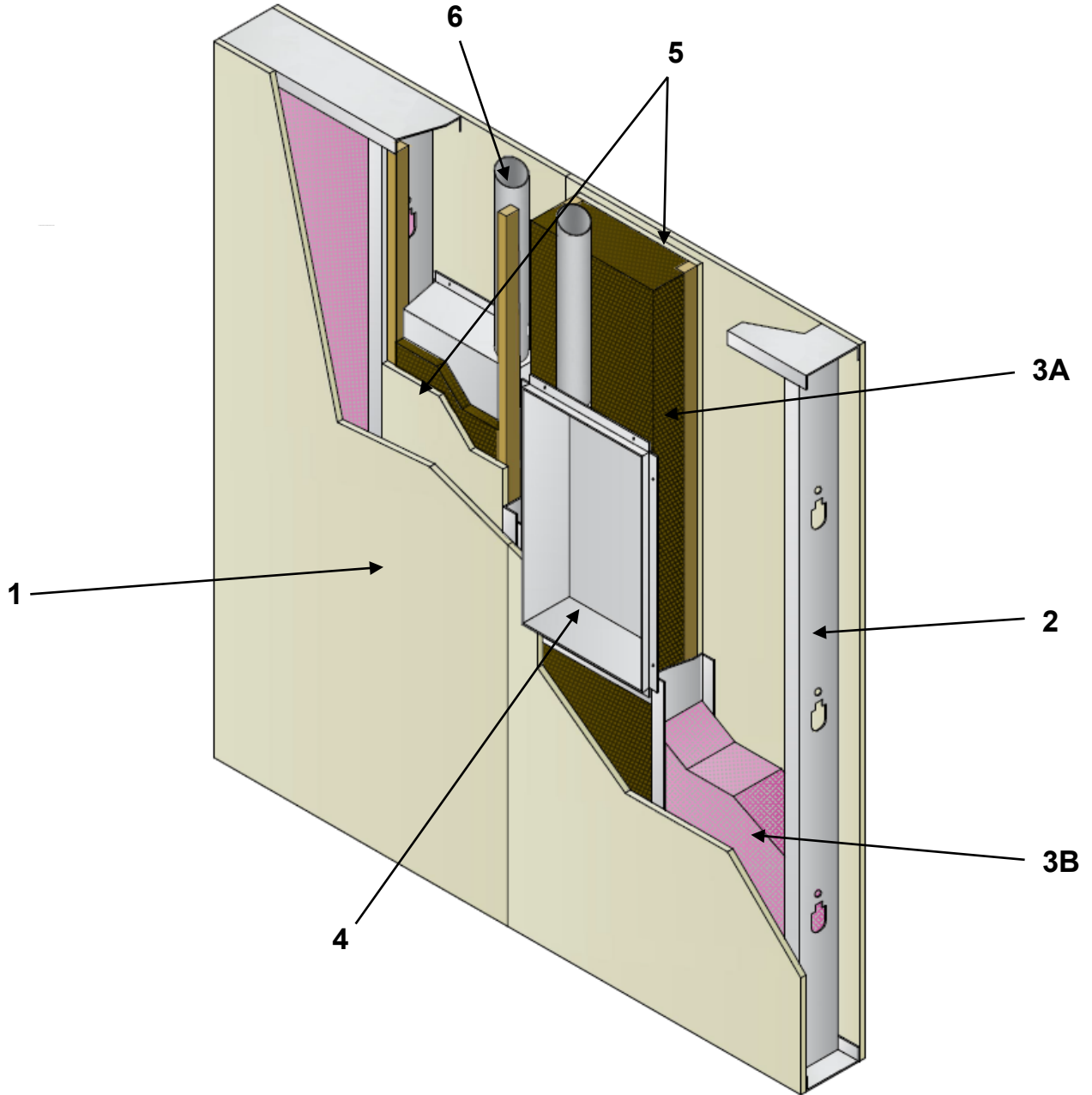

No.	COMPONENT	DESCRIPTION								
1	Gypsum Board Sheathing	Type: Type X gypsum wallboard complying with ASTM C1396 and labeled by an approved agency.								
		Thickness: <table border="1" style="width: 100%;"> <tr> <td style="width: 50%;">1-Hour Rating: One layer of 5/8 in. (16 mm) on each face of the wall.</td> <td style="width: 50%;">2-Hour Rating (not shown): Two layers of 5/8 in. (16 mm) on each face of the wall.</td> </tr> </table>	1-Hour Rating: One layer of 5/8 in. (16 mm) on each face of the wall.	2-Hour Rating (not shown): Two layers of 5/8 in. (16 mm) on each face of the wall.						
		1-Hour Rating: One layer of 5/8 in. (16 mm) on each face of the wall.	2-Hour Rating (not shown): Two layers of 5/8 in. (16 mm) on each face of the wall.							
		Application: <table border="1" style="width: 100%;"> <tr> <td style="width: 50%;">Installed vertically with joints located over stud locations. On each side, one layer of 5/8 in. (16 mm) Type X is attached to the steel studs with minimum #6 x 1-5/8-inch (41 mm) self-drilling drywall screws spaced at 12 in. (305 mm) around the perimeter and in the field.</td> <td style="width: 50%;">Installed vertically with joints offset 24-inches (610 mm) from base layer. The second layer of 5/8 in. (16 mm) Type X is attached with minimum #6 x 2-1/4 inch (57 mm) self-drilling drywall screws spaced at 8 in. (203 mm) around the perimeter and 12 in. (305 mm) in the field.</td> </tr> </table>	Installed vertically with joints located over stud locations. On each side, one layer of 5/8 in. (16 mm) Type X is attached to the steel studs with minimum #6 x 1-5/8-inch (41 mm) self-drilling drywall screws spaced at 12 in. (305 mm) around the perimeter and in the field.	Installed vertically with joints offset 24-inches (610 mm) from base layer. The second layer of 5/8 in. (16 mm) Type X is attached with minimum #6 x 2-1/4 inch (57 mm) self-drilling drywall screws spaced at 8 in. (203 mm) around the perimeter and 12 in. (305 mm) in the field.						
Installed vertically with joints located over stud locations. On each side, one layer of 5/8 in. (16 mm) Type X is attached to the steel studs with minimum #6 x 1-5/8-inch (41 mm) self-drilling drywall screws spaced at 12 in. (305 mm) around the perimeter and in the field.	Installed vertically with joints offset 24-inches (610 mm) from base layer. The second layer of 5/8 in. (16 mm) Type X is attached with minimum #6 x 2-1/4 inch (57 mm) self-drilling drywall screws spaced at 8 in. (203 mm) around the perimeter and 12 in. (305 mm) in the field.									
Exposed joints to be taped and mudded. Fastener heads to be mudded for a monolithic surface. Follow ASTM C840 for level of finish.										
2	Wall Studs	Stud Type: Minimum 6 in. (152 mm) steel stud with 1-1/4 in. (32 mm) Flange.								
		Gauge: Minimum 25 Gauge.								
		Stud Spacing: Maximum 16 in. (406 mm) on center.								
3A	Insulation (Dryer Vent Box Cavity)	Type: Mineral wool firestopping insulation, compliant to ASTM C612 Type IVA or CAN/ULC S702 Type 1 and non-combustible as defined by ASTM E136 or CAN/ULC-S114.								
		Nominal Density: Minimum 4.0 lb/ft ³ (64 kg/m ³).								
		Installation: 1 in. mineral wool firestopping insulation shall be installed behind the dryer vent box. Remainder of the cavity shall be filled with non-combustible mineral wool firestopping insulation including between the box and the steel stud.								
3B	Insulation (Adjacent Cavities)	Type: Minimum R-19 unfaced fiberglass batt insulation, complaint to ASTM C665 Type 1 or CAN/ULC S701 Type 1 and non-combustible as defined by ASTM E136 or CAN/ULC-S114.								
		Minimum Thickness: 6 inch (152 mm).								
		Installation: Fiberglass batt must be installed in the adjacent cavities.								
4	Dryer Vent Box	Certified Manufacturer: Construction Solutions, LLC.								
		Certified Products and Box Dimensions: <table border="1" style="width: 100%;"> <tr> <td style="width: 30%;">DBX1000M 4 in. Metal Dryer Vent Box with Snap on Trim Ring</td> <td>10 in. (254 mm) wide by 17 in. (432 mm) high by 3-1/2 in. (89 mm) deep with a 1-1/4 in. (32 mm) flange. A 3 x 5 in. (76 x 127 mm) oval cut out for the dryer vent on the top and 1-1/8 in. (29 mm) knockouts on the top and bottom for gas hook up. The box is formed from 22 Gauge galvanized steel.</td> </tr> <tr> <td>DBX1017FR4 3.5 in. Metal Dryer Vent Box</td> <td>10.77 in. wide by 17.82 in. high by 4 1/4 in. deep with a 1 in. flange. A 3.157 in. cut out for the dryer vent. 1-1/8 in. knockout on the top of the box. The box is formed from 24 Gauge steel.</td> </tr> <tr> <td>DBX1017FR 4.25 in. Metal Dryer Vent Box</td> <td>10 in. (254 mm) wide by 17 in. (432 mm) high by 4.25 in. (108 mm) deep with a 1 in. (25 mm) flange. A 4 in. (102 mm) cut out for the dryer vent on the top and 1-1/8 in. (29 mm) knockout on the top. The box is formed from 24 Gauge steel.</td> </tr> <tr> <td>DBX1424 4.25 in. Metal Dryer Vent Box</td> <td>14 in. (356 mm) wide by 24 in. (610 mm) high by 4.25 in. (108 mm) deep with a 1 in. (25 mm) flange. A 4 in. (102 mm) cut out for the dryer vent. 1-1/8 in. (29 mm) knockout on the top of the box. 24 Gauge steel.</td> </tr> </table>	DBX1000M 4 in. Metal Dryer Vent Box with Snap on Trim Ring	10 in. (254 mm) wide by 17 in. (432 mm) high by 3-1/2 in. (89 mm) deep with a 1-1/4 in. (32 mm) flange. A 3 x 5 in. (76 x 127 mm) oval cut out for the dryer vent on the top and 1-1/8 in. (29 mm) knockouts on the top and bottom for gas hook up. The box is formed from 22 Gauge galvanized steel.	DBX1017FR4 3.5 in. Metal Dryer Vent Box	10.77 in. wide by 17.82 in. high by 4 1/4 in. deep with a 1 in. flange. A 3.157 in. cut out for the dryer vent. 1-1/8 in. knockout on the top of the box. The box is formed from 24 Gauge steel.	DBX1017FR 4.25 in. Metal Dryer Vent Box	10 in. (254 mm) wide by 17 in. (432 mm) high by 4.25 in. (108 mm) deep with a 1 in. (25 mm) flange. A 4 in. (102 mm) cut out for the dryer vent on the top and 1-1/8 in. (29 mm) knockout on the top. The box is formed from 24 Gauge steel.	DBX1424 4.25 in. Metal Dryer Vent Box	14 in. (356 mm) wide by 24 in. (610 mm) high by 4.25 in. (108 mm) deep with a 1 in. (25 mm) flange. A 4 in. (102 mm) cut out for the dryer vent. 1-1/8 in. (29 mm) knockout on the top of the box. 24 Gauge steel.
		DBX1000M 4 in. Metal Dryer Vent Box with Snap on Trim Ring	10 in. (254 mm) wide by 17 in. (432 mm) high by 3-1/2 in. (89 mm) deep with a 1-1/4 in. (32 mm) flange. A 3 x 5 in. (76 x 127 mm) oval cut out for the dryer vent on the top and 1-1/8 in. (29 mm) knockouts on the top and bottom for gas hook up. The box is formed from 22 Gauge galvanized steel.							
		DBX1017FR4 3.5 in. Metal Dryer Vent Box	10.77 in. wide by 17.82 in. high by 4 1/4 in. deep with a 1 in. flange. A 3.157 in. cut out for the dryer vent. 1-1/8 in. knockout on the top of the box. The box is formed from 24 Gauge steel.							
		DBX1017FR 4.25 in. Metal Dryer Vent Box	10 in. (254 mm) wide by 17 in. (432 mm) high by 4.25 in. (108 mm) deep with a 1 in. (25 mm) flange. A 4 in. (102 mm) cut out for the dryer vent on the top and 1-1/8 in. (29 mm) knockout on the top. The box is formed from 24 Gauge steel.							
		DBX1424 4.25 in. Metal Dryer Vent Box	14 in. (356 mm) wide by 24 in. (610 mm) high by 4.25 in. (108 mm) deep with a 1 in. (25 mm) flange. A 4 in. (102 mm) cut out for the dryer vent. 1-1/8 in. (29 mm) knockout on the top of the box. 24 Gauge steel.							
		Sealing: PFP 4800DW, Hilti FS-ONE MAX, STI LC Endothermic Firestop Sealant, 3M Fire Barrier Sealant CP 25WB+, WF300 Intumescent Caulking, Foil Tape listed to UL 723.								
Installation: The dryer vent box is fastened to the stud and sill through two holes on the side and bottom of the box using #8 x 5/8 in. (16 mm) self-drilling screws. The galvanized steel dryer vent is inserted through the top of the box then caulked at the vent/box interface. The opening cut into the gypsum board shall be a maximum of 10-1/2 in. (267 mm) wide by 17- 1/2 in. (445 mm) high. Only one box is permitted per stud cavity.										
Type: Type X gypsum wallboard complying with ASTM C1396 and labeled by an approved agency.										
Thickness: Single layer of 5/8 in. (16 mm).										
Application: The cavity containing the dryer vent box shall have a layer of 5/8 in. (16 mm) Type X gypsum placed behind the box. The gypsum shall be fastened to two 3/4 in. (19 mm) by 1-1/2 in. (38 mm) wood strips fastened to the stud with steel stud screws such that the gypsum will be flush with the 1-1/4 in. (32 mm) face of the studs prior to fastening the sheathing. The gypsum board shall be fastened with #6 x 1-5/8 in. (41 mm) drywall screws.										
6	Vent Pipe	Size: 4 in. (101 mm) round.								
		Type: 26 Gauge galvanized steel.								

TESTING AGENCY

Construction Solutions chose QAI laboratories

based in Canada to perform testing on our metal dryer vent boxes. QAI is recognized by UL as a thirdparty testing agency.

The following pages have information on our DBX1000M testing results as well as our DBX1017FR dryer vent box.





INTERNATIONAL
ACCREDITATION
SERVICE®

CERTIFICATE OF ACCREDITATION

This is to attest that

QAI LABORATORIES LTD.

3980 NORTH FRASER WAY
BURNABY, BRITISH COLUMBIA V5J 5K5
CANADA

Product Certification Agency PCA-118
Third-Party Certification Body

has met the requirements of the applicable provisions of AC370, *IAS Accreditation Criteria for Product Certification Agencies*, has demonstrated compliance with ISO/IEC Standard 17065:2012, *Conformity assessment - Requirements for bodies certifying products, process and services*. This organization is accredited to provide the services specified in the scope of accreditation maintained on the IAS website (www.iasonline.org).

This certificate is valid up to January 1, 2022.



This accreditation certificate supersedes any IAS accreditation bearing an earlier effective date. The certificate becomes invalid upon suspension, cancellation or revocation of accreditation. See www.iasonline.org for current accreditation information, or contact IAS at 562-364-8201.



C.P. Ramani

C.P. Ramani, P.E., C.B.O
President

7-13882



INTERNATIONAL
ACCREDITATION
SERVICE®

CERTIFICATE OF ACCREDITATION

This is to attest that

QAI LABORATORIES LTD.

3980 NORTH FRASER WAY
BURNABY, BC V5J 5K5
CANADA

Testing Laboratory TL-239

has met the requirements of AC89, *IAS Accreditation Criteria for Testing Laboratories*, and has demonstrated compliance with ISO/IEC Standard 17025:2017, *General requirements for the competence of testing and calibration laboratories*. This organization is accredited to provide the services specified in the scope of accreditation maintained on the IAS website (www.iasonline.org).

This certificate is valid up to January 1, 2022.



This accreditation certificate supersedes any IAS accreditation bearing an earlier effective date. The certificate becomes invalid upon suspension, cancellation or revocation of accreditation. See www.iasonline.org for current accreditation information, or contact IAS at 562-364-8201.



Raj Nathan

Raj Nathan
President

18-15965



June 24, 2015

To: Whom it may Concern

RE: QAI Laboratories Accreditations

QAI Laboratories is an international company with 4 offices in the US and 3 offices in Canada. QAI is accredited in both the United States and Canada. In the United States QAI Laboratories is accredited by the US Government Department of Labor, Occupational Safety and Health Administration (OSHA) as a Nationally Recognized Testing Laboratory (NRTL), we are also accredited by the International Accreditation Services (IAS) as a Testing Laboratory and a Certification Agency and by the American Association of Laboratory Accreditation (A2LA) and the Federal Communication Commission (FCC) as an EMC/EMI testing laboratory and Conformity Assessment Body (CAB). In Canada we are accredited by the Standards Council of Canada (SCC) and also Industry Canada (IC) for (EMC/EMI).

With specific reference to Fire resistance evaluation of products our scope of accreditation is equivalent to that of other agencies like UL or Intertek. We are all accredited by the above noted agencies to ISO 17065 standard for Certification of Fire rated products and the ISO 17025 standard for testing of these products. It should also be noted QAI is a major partner to ICC-ES providing many of their testing and inspection services.

For details of our scope please visit <http://qai.org/accreditations/>

For specifics on the Constructions Solutions listing and use limitations please see QAI's online listing page at:

<http://www.qai.org/Listing Pages/QAI Listing B1072 Construction Solutions.htm>

Should you require any additional information on our accreditations please do not hesitate to call **604-527-8378**.

Regards

Lawrence Gibson, P. Eng.,
President